

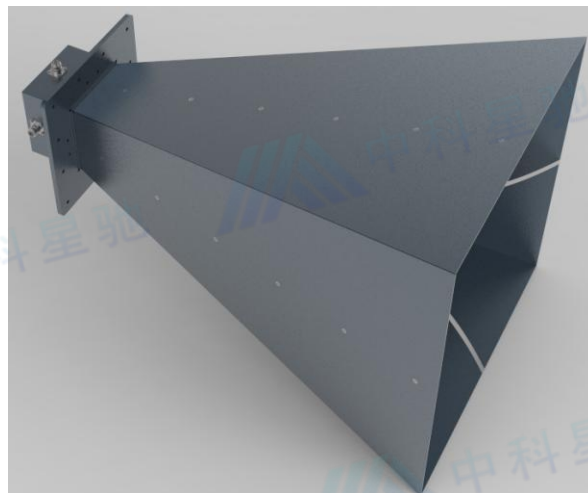

## 技术规格书

### 双极化喇叭天线

| 项目   | 指标          | 单位  |
|------|-------------|-----|
| 型号   | ZK-SJLB0730 |     |
| 频率   | 0.7-3       | GHz |
| 增益   | $\geq 10$   | dB  |
| 驻波   | 1.5 典型值.    |     |
| 极化方式 | 双线极化        |     |
| 接头   | N-50K       |     |
| 功率   | 50 最大       |     |
| 材料   | 铝           |     |
| 颜色   | 海灰色         |     |
| 尺寸   | 790*503*503 | 毫米  |





# 成都中科星驰科技有限公司

外形图:

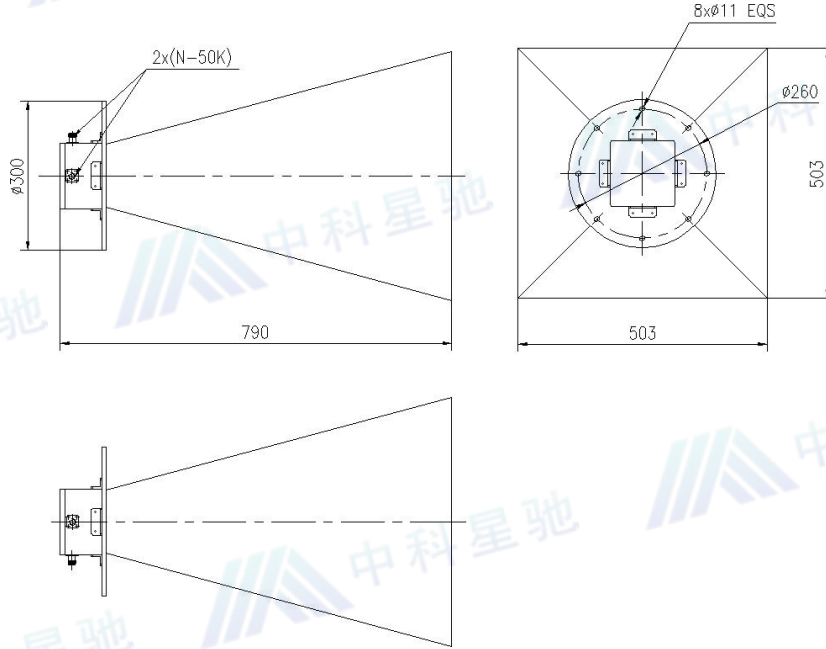

驻波:





# 成都中科星驰科技有限公司

增益:

