



# 成都中科星驰科技有限公司

## 技术规格书

### 双极化喇叭天线

项目	指标	单位
型号	ZK-SJLB20180	
频率	2-18	GHz
增益	12 典型值	dB
驻波	2 典型值	
极化方式	双线极化	
接头	SMA-50K	
功率	50 最大	
材料	铝	
颜色	海灰色	
尺寸	213*79*79	毫米

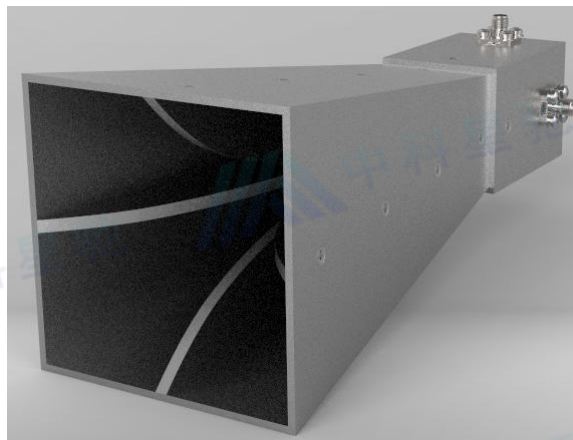



# 成都中科星驰科技有限公司

外形图:

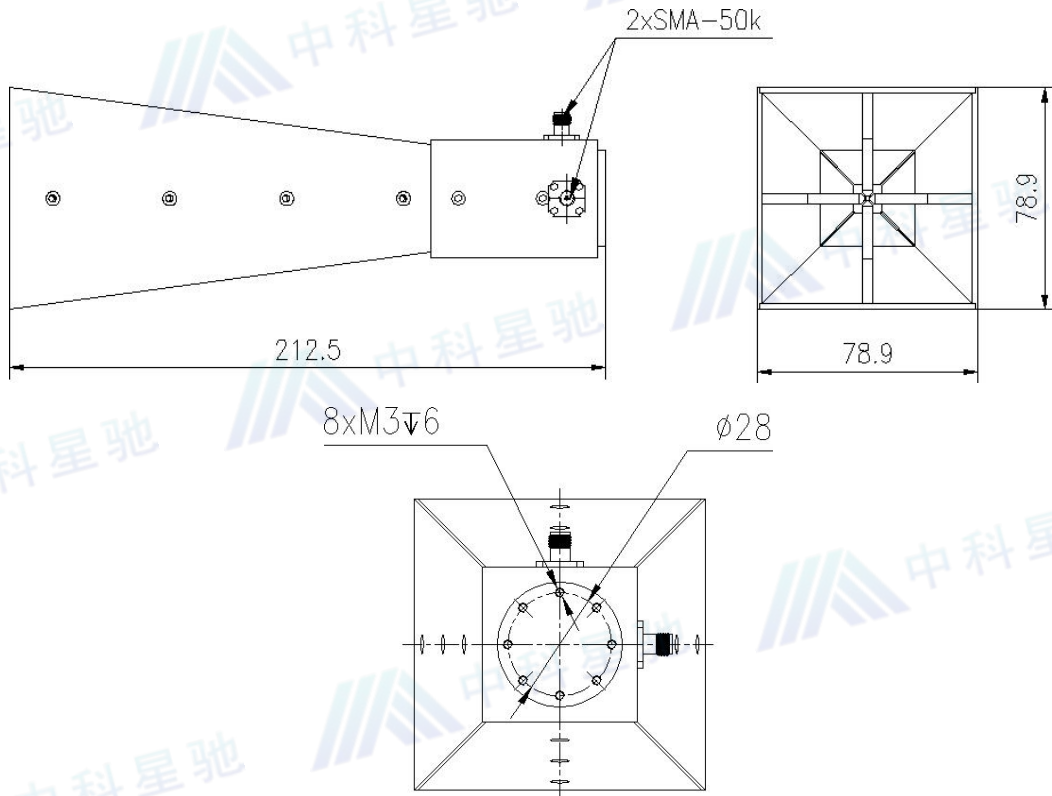

驻波:

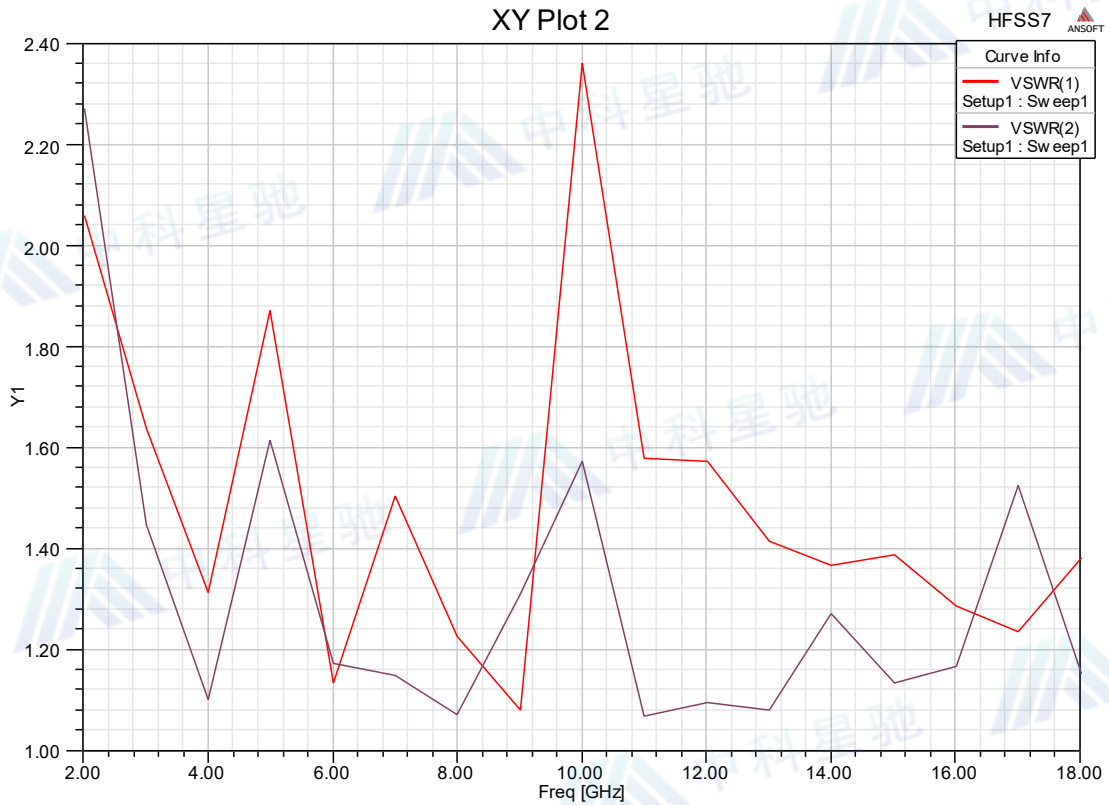



# 成都中科星驰科技有限公司

增益方向图:

Name	Theta	Ang	Mag
mt	0.0000	0.0000	5.7628

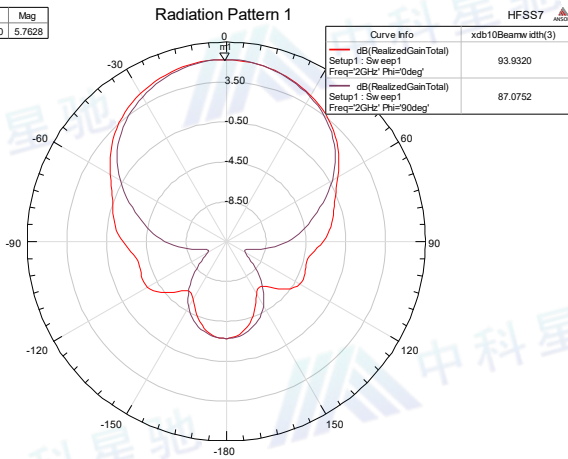

Name	Theta	Ang	Mag
mt	0.0000	0.0000	8.4589

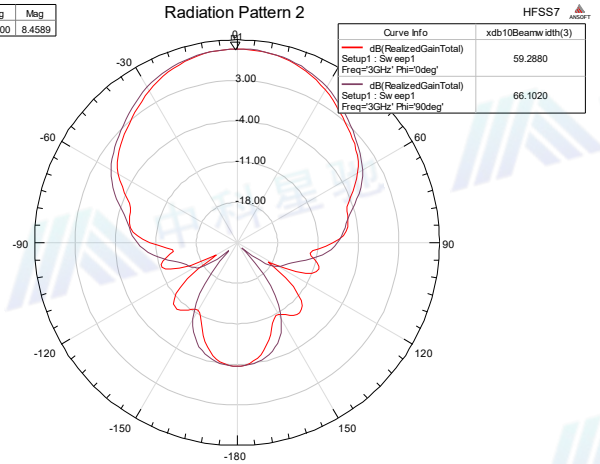

Name	Theta	Ang	Mag
mt	0.0000	0.0000	10.3353

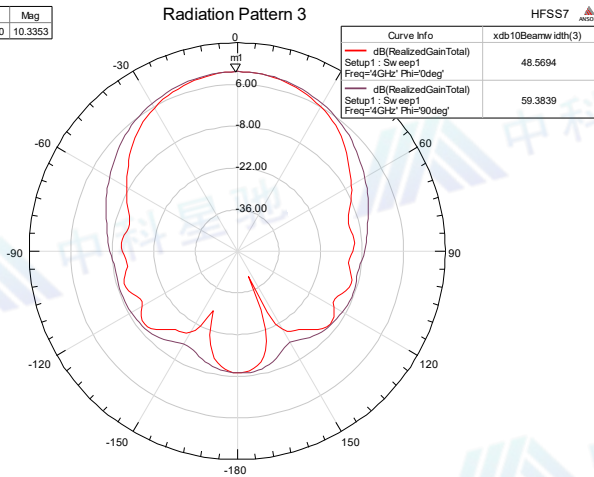

Name	Theta	Ang	Mag
mt	0.0000	0.0000	11.9440

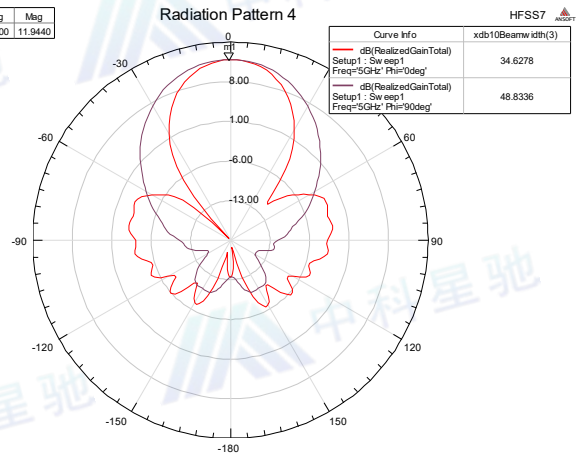

Name	Theta	Ang	Mag
mt	0.0000	0.0000	12.3815

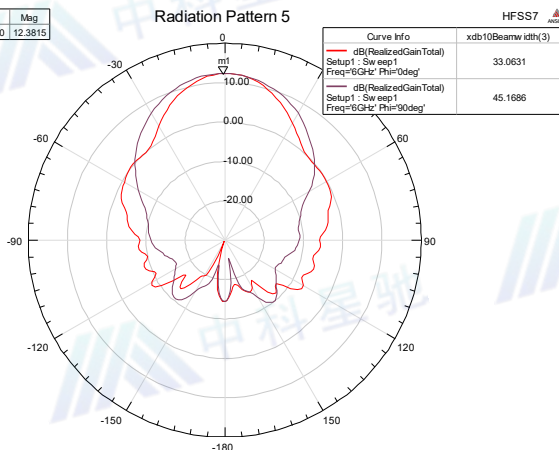

Name	Theta	Ang	Mag
mt	0.0000	0.0000	13.8583

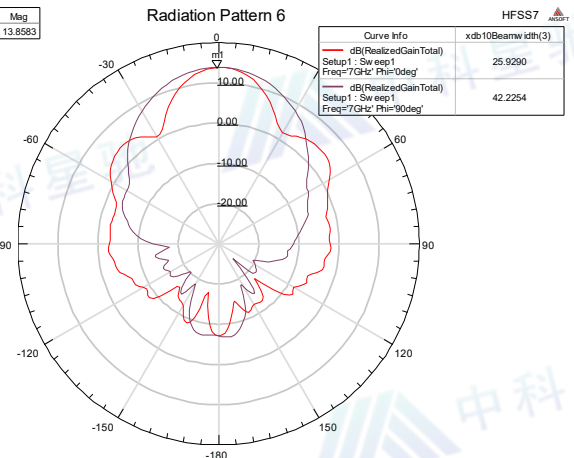



# 成都中科星驰科技有限公司

Name	Theta	Ang	Mag
m1	0.0000	0.0000	14.6092

### Radiation Pattern 7

HFSS7

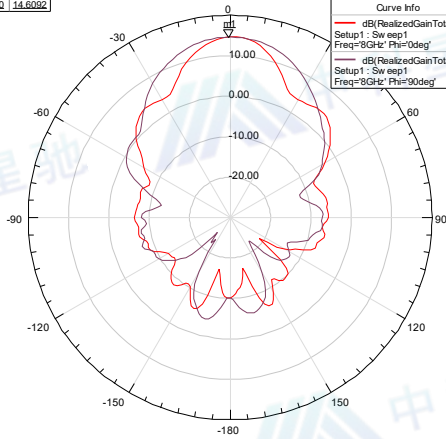

Curve Info		xcdb10Beamwidth(3)
dB(RealizedGainTotal)	Setup1: Sw eep1	25.1973
dB(RealizedGainTotal)	Setup1: Sw eep1	40.8737

Name	Theta	Ang	Mag
m1	0.0000	0.0000	14.9949

### Radiation Pattern 8

HFSS7

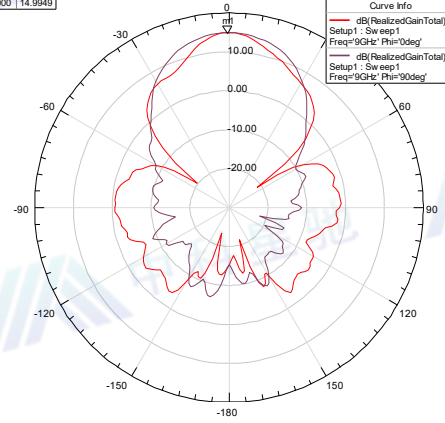

Curve Info		xcdb10Beamwidth(3)
dB(RealizedGainTotal)	Setup1: Sw eep1	24.7035
dB(RealizedGainTotal)	Setup1: Sw eep1	39.2427

Name	Theta	Ang	Mag
m1	0.0000	0.0000	16.6150

### Radiation Pattern 9

HFSS7

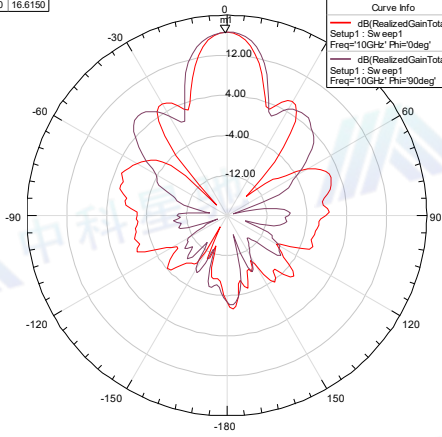

Curve Info		xcdb10Beamwidth(3)
dB(RealizedGainTotal)	Setup1: Sw eep1	17.3033
dB(RealizedGainTotal)	Setup1: Sw eep1	21.9914

Name	Theta	Ang	Mag
m1	0.0000	0.0000	19.1956

### Radiation Pattern 10

HFSS7

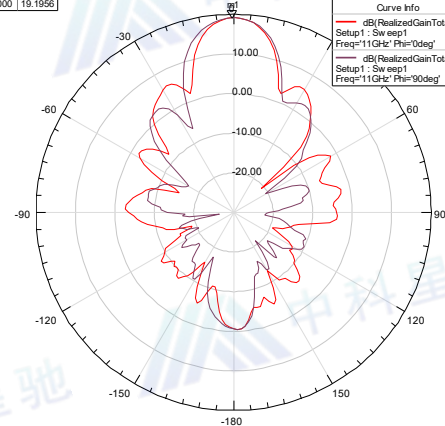

Curve Info		xcdb10Beamwidth(3)
dB(RealizedGainTotal)	Setup1: Sw eep1	18.3734
dB(RealizedGainTotal)	Setup1: Sw eep1	21.0286

Name	Theta	Ang	Mag
m1	0.0000	0.0000	17.2142

### Radiation Pattern 11

HFSS7

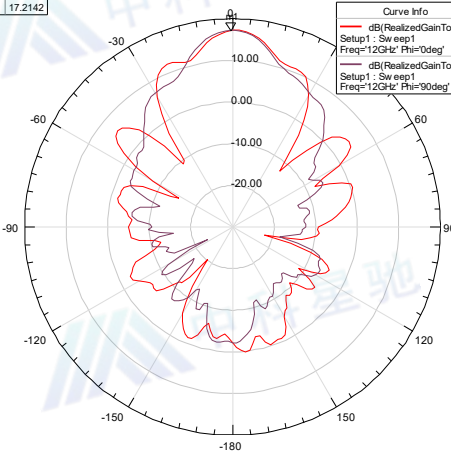

Curve Info		xcdb10Beamwidth(3)
dB(RealizedGainTotal)	Setup1: Sw eep1	19.7376
dB(RealizedGainTotal)	Setup1: Sw eep1	20.9275

Name	Theta	Ang	Mag
m1	0.0000	0.0000	12.6675

### Radiation Pattern 12

HFSS7

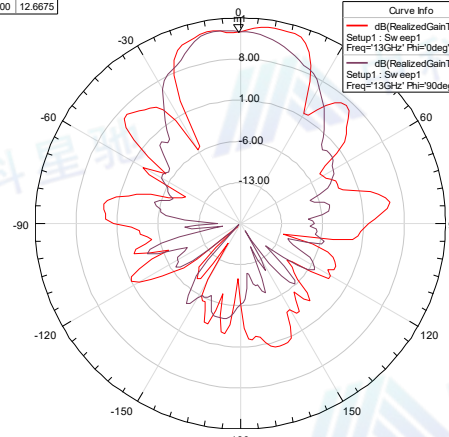

Curve Info		xcdb10Beamwidth(3)
dB(RealizedGainTotal)	Setup1: Sw eep1	43.5391
dB(RealizedGainTotal)	Setup1: Sw eep1	37.2598



# 成都中科星驰科技有限公司

Name	Theta	Ang	Mag
m1	0.0000	0.0000	15.3250

### Radiation Pattern 13

HFSS7

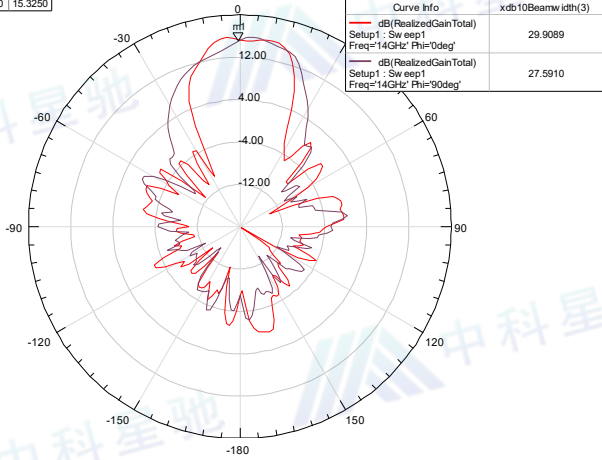

Name	Theta	Ang	Mag
m1	0.0000	0.0000	18.4529

### Radiation Pattern 14

HFSS7

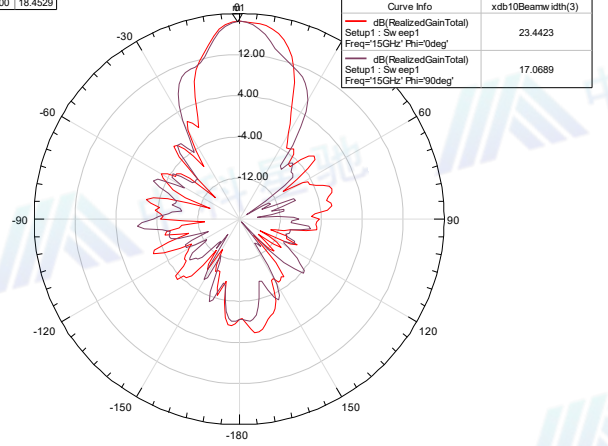

Name	Theta	Ang	Mag
m1	0.0000	0.0000	20.8868

### Radiation Pattern 15

HFSS7

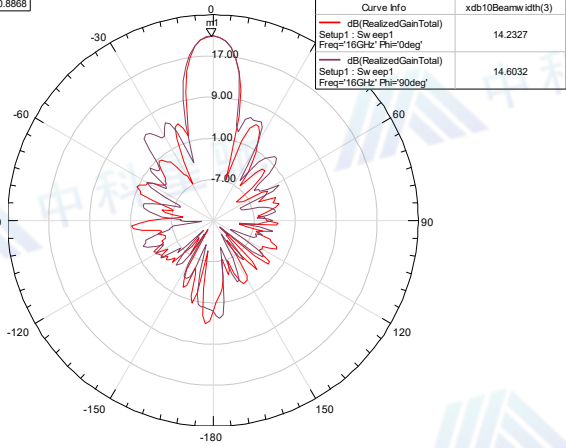

Name	Theta	Ang	Mag
m1	0.0000	0.0000	20.9630

### Radiation Pattern 16

HFSS7

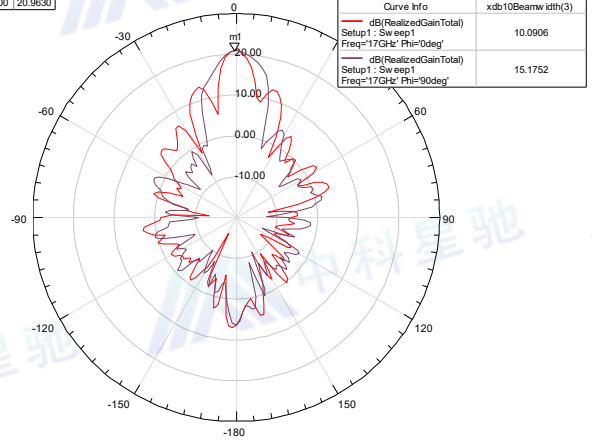

Name	Theta	Ang	Mag
m1	0.0000	0.0000	19.2403

### Radiation Pattern 17

HFSS7

